





■

						°C
					°C	
						°C

■

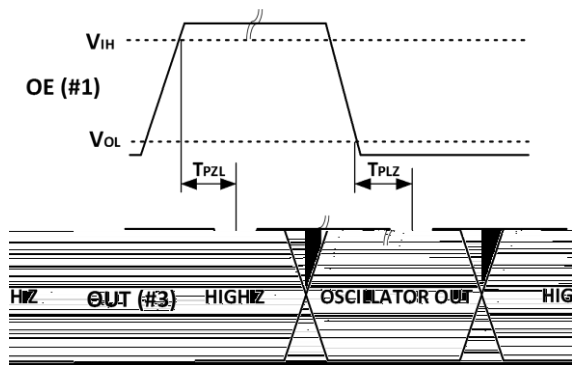
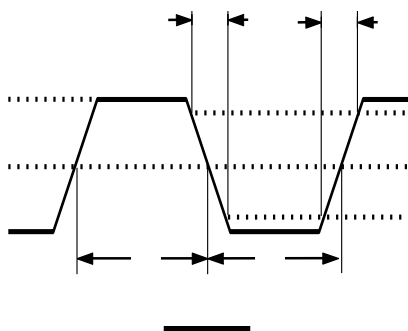
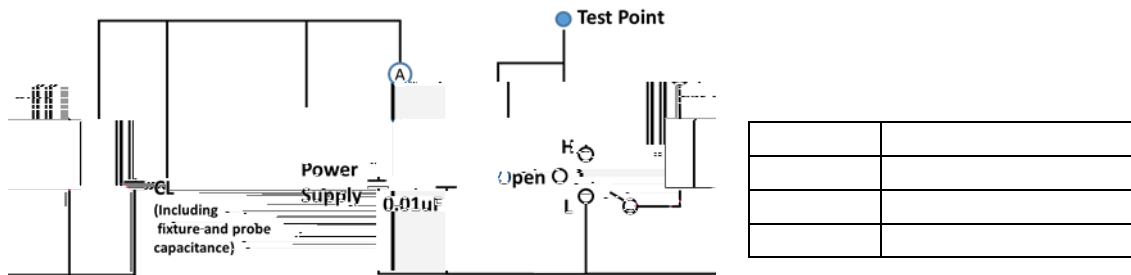

TOP VIEW

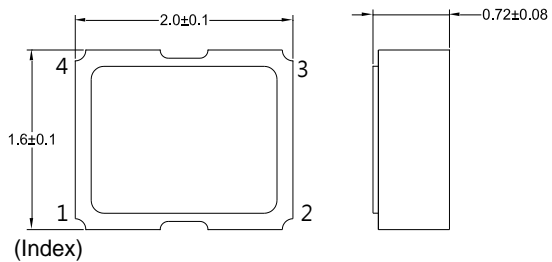

BOTTOM VIEW

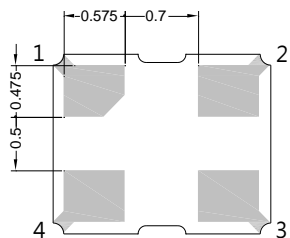

**TOP VIEW
Land Pattern Layout**

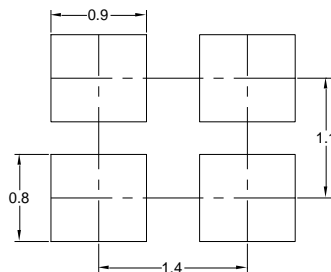

Pin Connections	
1	OE(Output Enable)
2	GND
3	Output
4	Vdd

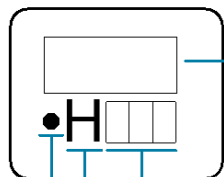

Nominal frequency
ex. 26 MHz=>26.0

#1 Pin Location

H.ELE.

Date Code:YWW

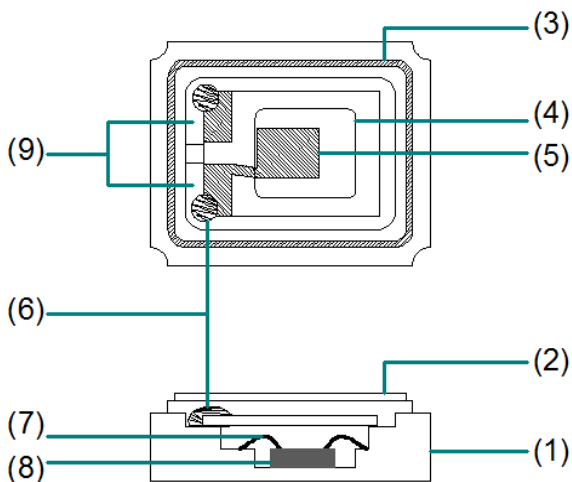

※

■

■

°C

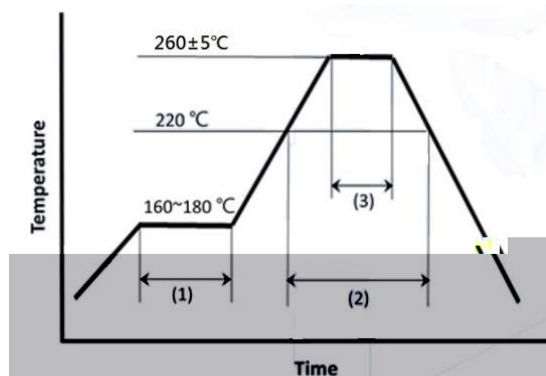





■

■

■

Horizontal bar

Horizontal bar

Vertical bar

Horizontal bar

Horizontal bar

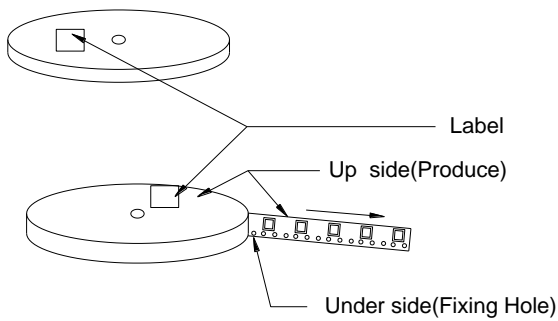
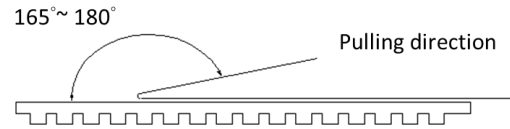

One reel quantity: [1000pcs]&[3000pcs]

- ① Top and bottom with 2.3cm thickness foam-rubber cushion for protection.
- ② Carton's Q'TY: 1~15 pcs.
- ③ Carton Type=A,B,C use 4 trigon pilla

Label Contents

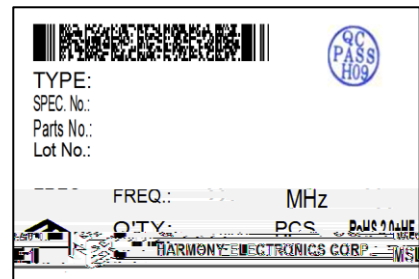

The label will be stickled on all reels.

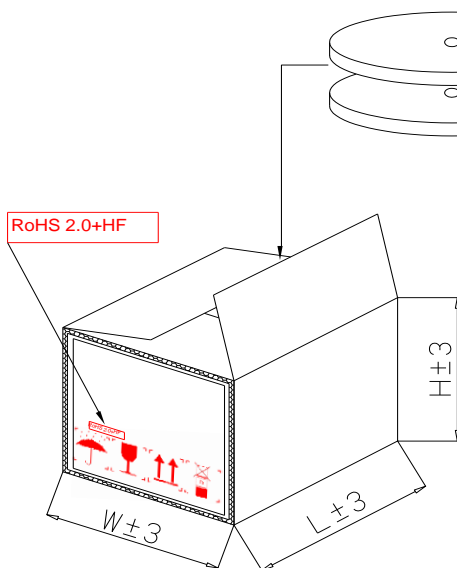
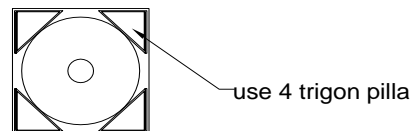

Carton Type	A	B	C	D
Produce Type	840/751	630/531/ 421	321/221 211/111	OTHER
Reel	15	15	15	1~7
L±3	200	200	200	195
W±3	200	200	200	195
H±3	230/260	230	230	150



		:	
		°C	
		°C	

		°C °C	
		°C °C	
		°C °C	
		°C °C	
		:	



加高電子股份有限公司
HARMONY ELECTRONICS CORP.

